

Item	QTY	Description
1	1	44" Vertical Extrusion
2	1	44" Vertical Extrusion
3,3A	1,1	31.5" Horizontal Extrusion
4,4A	1,1	31.5" Horizontal Extrusion
5,5A	1,1	25.197" Horizontal Extrusion
6,6A	1,1	4.5" Vertical Extrusion
7,7A	1,1	26.5603" Curved Horizontal Extrusion

Steps:

- 1) Connect horizontals [3 to 3A] and [4 to 4A]. See **Straight** detail.
- 2) Connect verticals [1] and [2] with horizontal assemblies. See **Corner** detail.
- 3) Connect header assemblies [5/6/7] and [5A/6A/7A] together.
- 4) Attach assembled header to [4/4A]. using bolts, making sure Velcro is facing to BACK.
- 5) Connect Header graphic to Velcro.
- 6) Attach feet to verticals [1] and [2]. See **Foot Attachment** detail.
- 7) Apply graphic to assembled frame. See **SEG Graphic Installation** detail.

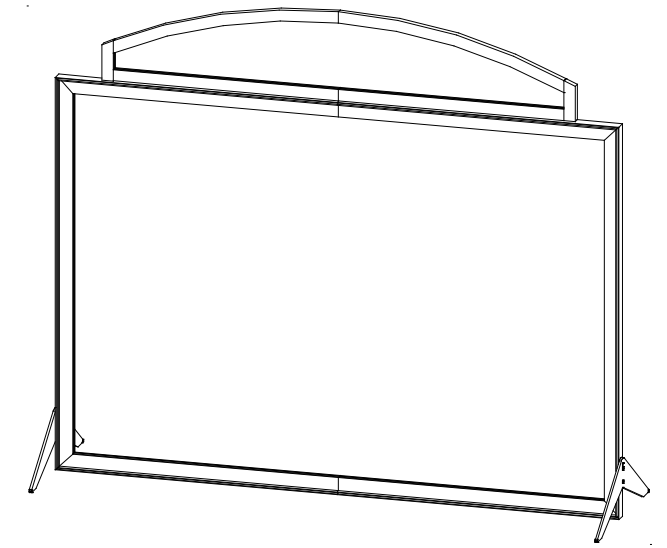

Completed Assembly

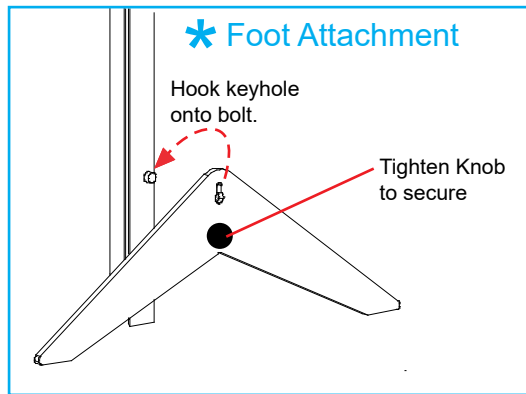

Keep extrusions [5/6/7] and [5A/6A/7A] assembled when packing.

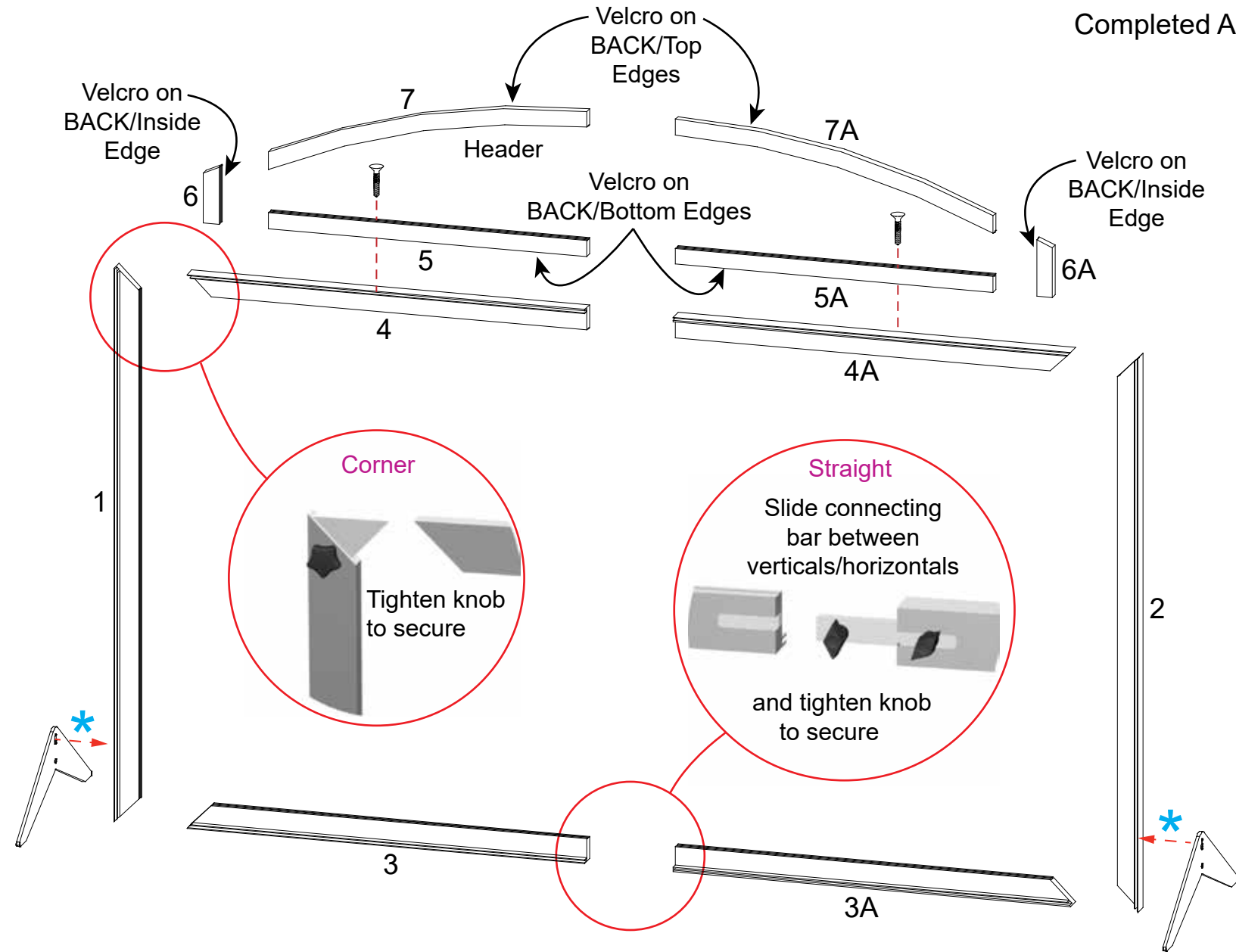

SEG Graphic Installation

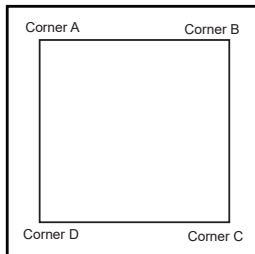

It is important to first insert graphic into each alternate corner then to the sides of the frame. If this is not done, graphic will not fit into the frame correctly.



Step 1
Insert corner A. Turn edge of graphic so silicon welt is perpendicular to face of graphic. Insert narrow side of welt with fabric to outside into the channel. Repeat for other side of this corner.



Step 2
Repeat Step 1 for opposite corner C, then insert corner B, followed by corner D, to complete the installation of the corners.

Graphic Removal



To remove the graphic from the frame, locate the fabric pull tab. Gently pull up on the tab to remove the fabric.



Step 3
Once all corners are inserted, press one silicon edge into channel from corners and work toward the center. Make sure welt is fully inserted into channel. Continue until all sides are done. Smooth out edges of graphic.

General Setup Instructions

- Read entire setup instruction manual prior to unpacking parts and pieces.
- The setup instructions are created specifically for this configuration.
- Setup instructions are laid out sequentially in steps, including exploded views with detailed explanation for assembly.

Cleaning & Packing

- For Cleaning Metal, Plex, & Laminate Parts: Use a **MILD NON-ABRASIVE** cleanser and soft cloth/paper towel to clean all surfaces.
- Keep exhibit components away from heat and prolonged sun exposure. **Heat and UV exposure will warp and fade components.**
- Retain all provided Packing Materials. All provided packing materials are for ease of repacking & component protection.

Disassembly

- For loss prevention, tighten all set screws and locks during disassembly.

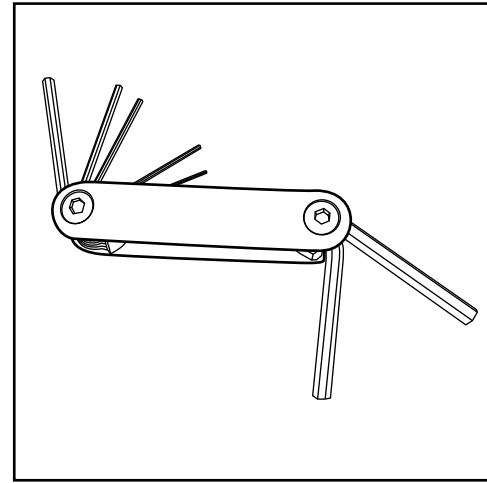

Hex Tool - Essential for Assembly

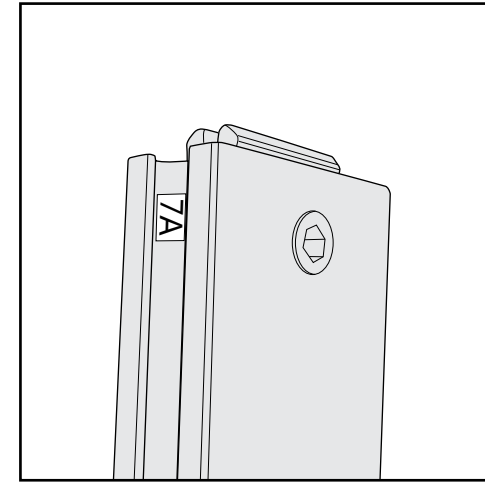

Part Identification - Numbering

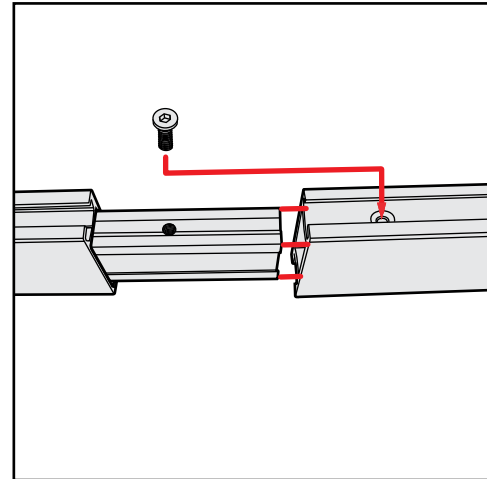

Spline Connection

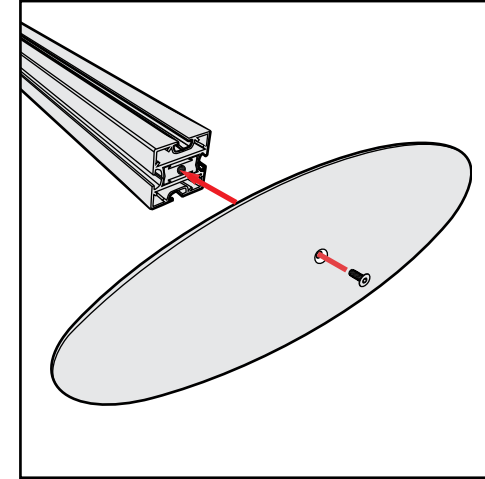

Base Plate & Extrusion Connection

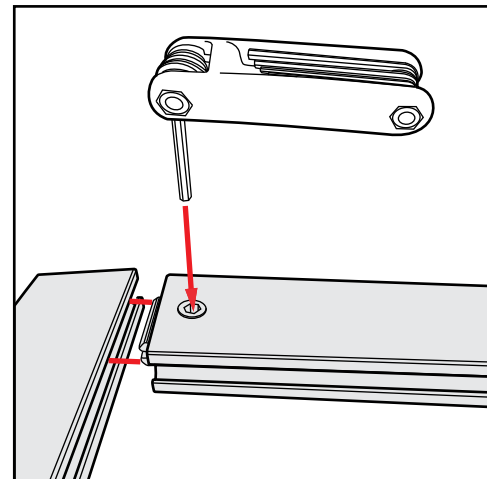

Extrusion & Lock Connection

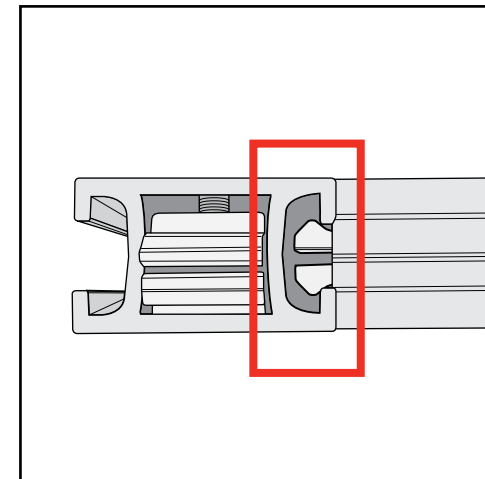

Engaged Lock



WARNING



DO NOT USE POWER TOOLS



LADDERS OR LIFTS
MAY BE REQUIRED



ALL CONNECTIONS MUST
BE TIGHTLY SECURED

Top View of Each Level

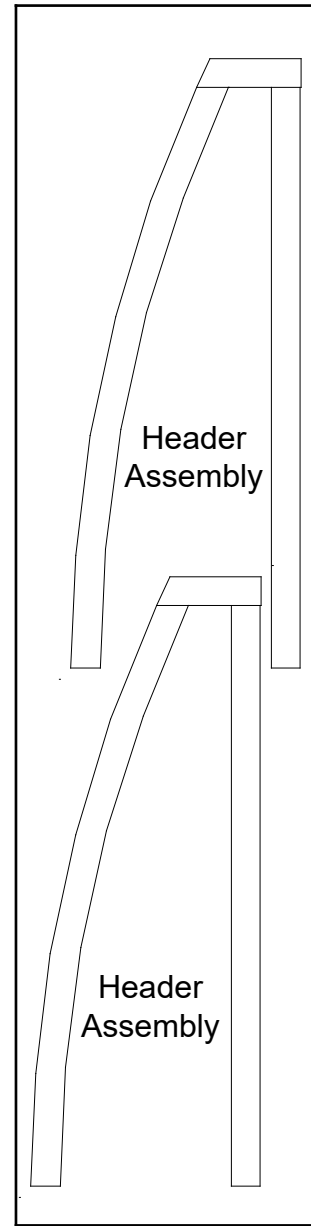

Level 1
(Bottom Level)

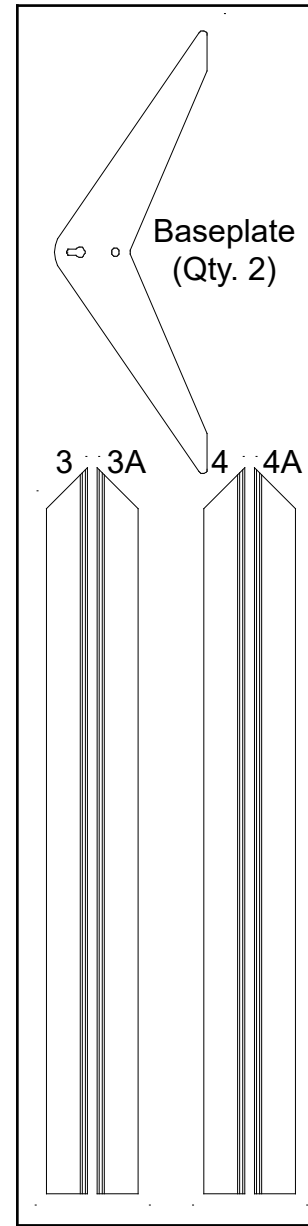

Level 2

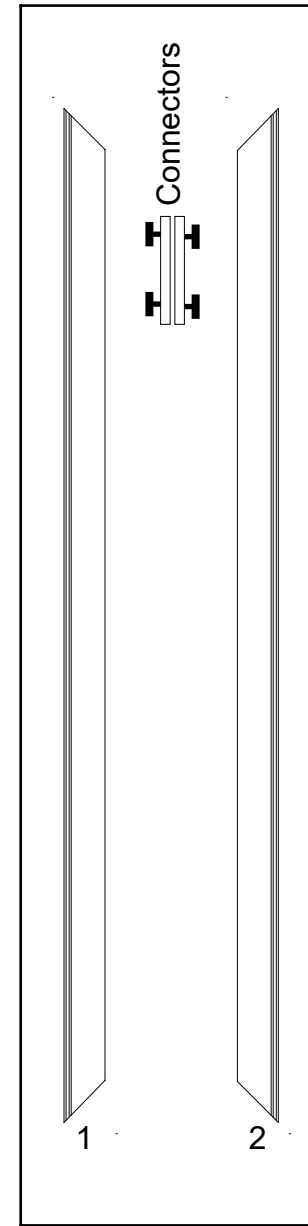

Level 3

Setup
Hardware
Bag

Graphics
Bag